

DP-5V

DP-5V

GEIGER COUNTER

Technical manual
and instructions for use

Copyright 2002 Viscom Inc.
English Translation by George Dowell and Daniel Novak

CONTENTS

1. Introduction	3
2. Purpose of unit	3
3. Operating data	3
4. Unit design	5
5. Composition and operating the unit	7
6. Marks and sealings	13
7. Directions for and after use	13
8. Indicators of safety	14
9. Preparation for work	14
10. Discipline of work	16
11. Characteristic defects and their repair	17
12. Maintenance engineering	20
13. Checking the unit	22
14. Safekeeping of unit	26
15. Transport	28

Additions

1. Circuit diagrams	29
2. Electrical diagram with a table	33
3. Table with ranges of the unit	36
4. Transformer data	37
Form for recording of radiation	38

DP5-V

Service and Operational Manual

English Translation by
George Dowell
And
Daniel Novak

Copyright 2002 Viscom Inc.

AA BATTERY ADAPTORS AVAILABLE FROM
KØFF@ARRL.NET

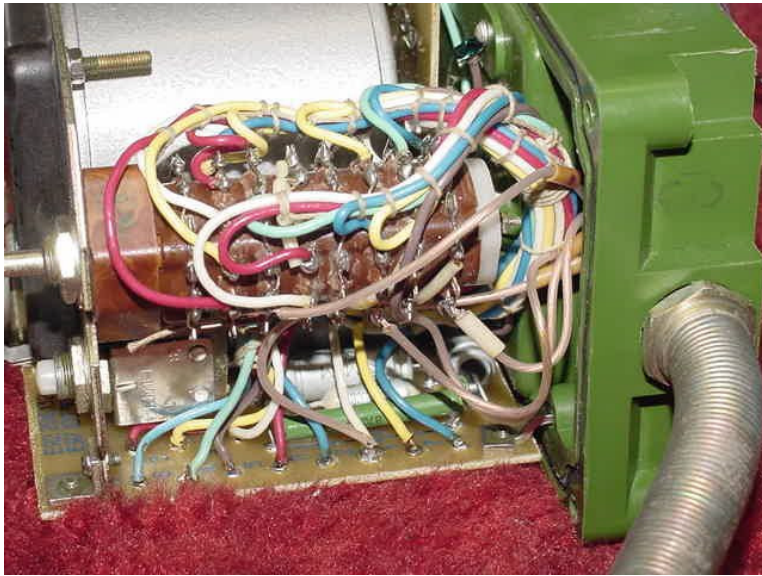

Range Switch Wiring

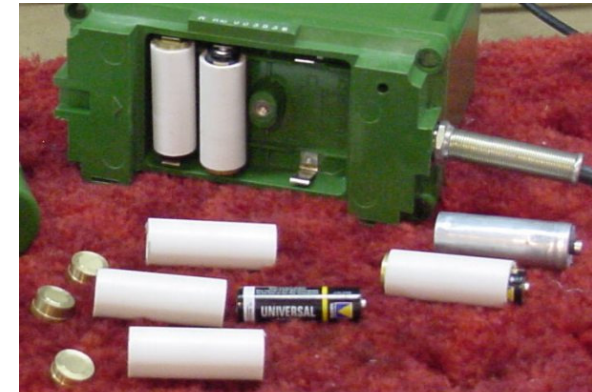

PROBE CIRCUIT BOARD

THYRATRON TUBES

G-M TUBES

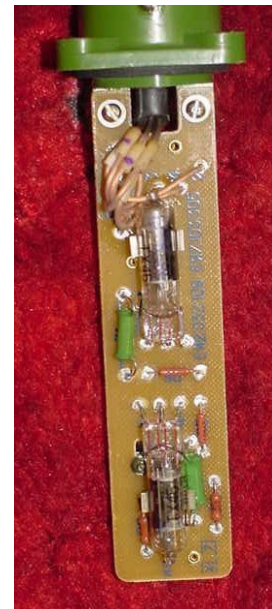
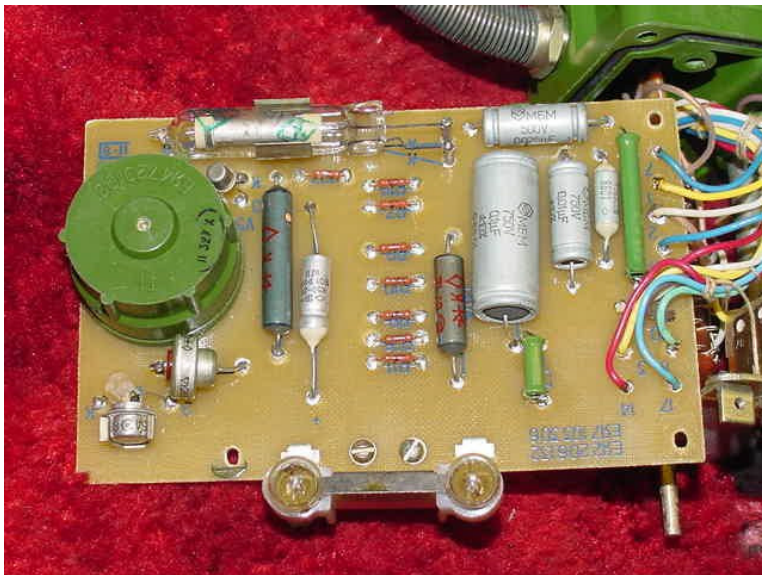

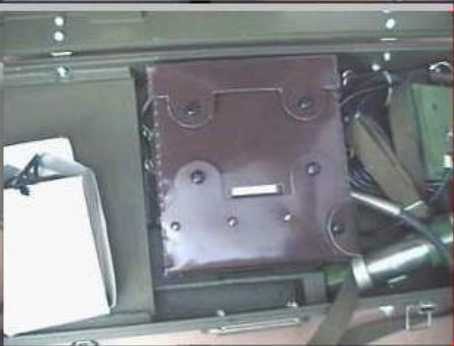

ДП-5В

...РЕНТГЕНА
...МОЩНОСТИ ДОЗЫ
... (СИМЕТР)

1. INTRODUCTION

This manual is intended for familiarization with the unit. It contains operation data and information about the construction and the operation principles, which are needed for correct and full use of all functions. Directions of use contain the rules of work, safety, transport and maintenance, so the unit can be always ready for use.

2. PURPOSE OF UNIT

This is a radiation meter (Roentgenmeter) DP-5V used to measure the Gamma radiation and to determine how high area contamination is, or to measure how contaminated items are..

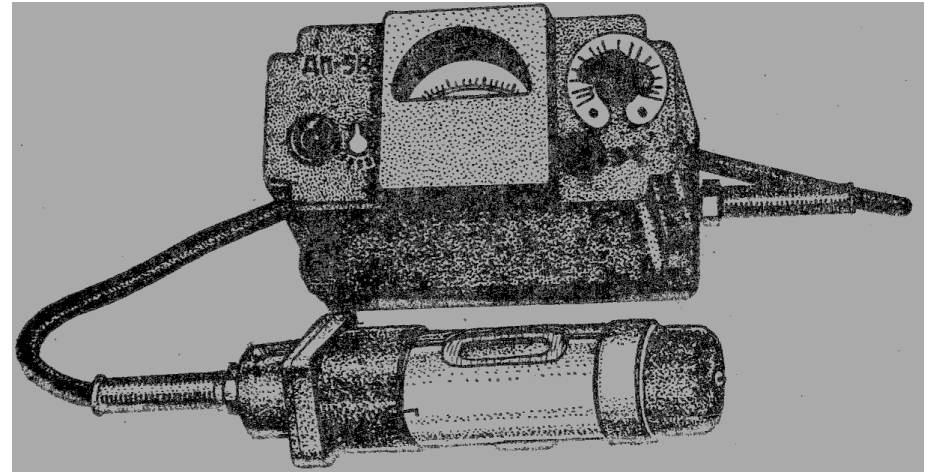

Picture 1. View of the unit

3. OPERATING DATA

This unit will show the measurement after one minute self warm-up. The measure range of Gamma radiation is from 0.05 mR/hr to 200 R/hr. The energy range is from 0.084 MeV thulium-170 to 1.25 MeV cobalt-60. This unit has 6 ranges for measuring the radiation (table 1)

3.2. The read-out of the data is made on the scale, which is multiplied with the relevant range coefficient.

3.3 The unit has earphones, which are working on all ranges, except the first (in roentgens)

table 1

Range number	Position of the range switch	Scale (on the meter)	Measurement units	Real range (after multiplying)
1	200	0-200	R/hr	5-200
2	x1000	0-5	mR/hr	500-5000
3	x100	0-5	mR/hr	50-500
4	x10	0-5	mR/hr	5-50
5	x1	0-5	mR/hr	0.5-5
6	x0.1	0-5	mR/hr	0.05-0.5

3.4 Instrument accuracy on any of its 6 ranges is within $\pm 30\%$ of true dose rate in normal climatic conditions.

(Note: We understand under normal climatic conditions: temperature 20 ± 5 °C, relative humidity 65 ± 15 %, atmospheric pressure 100 ± 4 kPa)

3.5. The instrument will work:

- in temperatures from -50 to $+50$ °C, relative air humidity $65 \pm 15\%$
- in conditions of relative air humidity $95 \pm 3\%$, in a temperature of 40 ± 2 °C
- after rain with an intensity of 5 ± 2 mm/min
- after immersing the measuring probe in a water, with a maximum deep of 0,5 m
- after stay in a dust environment

3.6. The dependency of the indicated dose rate from the energy of the Gamma radiation is not more than ± 40 %.

3.7 The dependency of the indicated dose rate from the direction of the ionizing radiation

Transformer Wiring

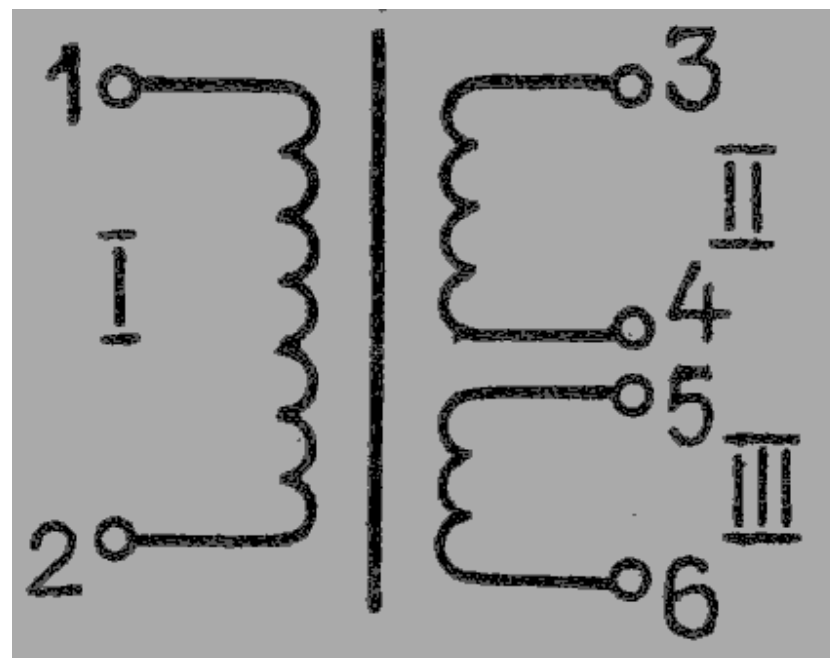

Transformer Resistance Test

Winding	read between	Measured Resistance
I	1-2	1800 Ohms
II	3-4	76 Ohms
III	5-6	12 Ohms

NOTES

is not more than

+/- 60 % by an energy of 1.25 MeV,

+/- 70% by an energy of 0.66 MeV,

+/-90% by an energy of 0.084 MeV

3.8. An additional error reading can be produced on every next 10 °C.

But the reading is not higher than:

a) +/- 10 % in temperature scale from 20 to 50 °C

b) +/- 5 % in temperature scale from 20 to -50 °C

3.9. The unit's needle won't go backwards if the radiation is not higher than 300 R/hr, on the 1-3 range; if it's not higher than 50 R/hr on the 4-6 range.

3.10. The needle on the unit will stabilize on a point within 45 seconds (measure time)

3.11. This unit is powered with 3 battery cells, battery type A336. One of them is used for the light under the scale. The meter will work at minimum 70 hours, in normal conditions, without the lighting (with new batteries, and the storage was not more than 1 month)

3.12. The meter will work after these mechanic and climatic conditions:

-vibrations in a range from 10 to 80 Hz, with an acceleration of 30 m/s²

-blows with a frequency of 80-120 blows per minute, with an acceleration of 150 m/s²

-transport vibrations with an acceleration of 1000 m/s² and with a frequency of 80-120 blows per minute

-a drop from an altitude of 500 mm

- temperatures from +60 to -50 °C

3.13. The size is not higher than: meter unit 82x134x163 mm, GM probe Ø50x164 mm, and telescopic wand with the GM probe 560-910mm, the whole case 4691x132x277mm.

3.14. The meter weights not more than 3.2 kg with the batteries. The whole kit (with case) weights 8.2 kg

4. UNIT DESIGN

The kit contains (picture 2):

A meter in a cover (2);

- A telescopic wand (1);
- A voltage divider (3) for connecting the unit to external energy sources, direct current, 12 V and 24 V.
- A manual (6)
- Earphones and some accessories (5)
- A case (4)

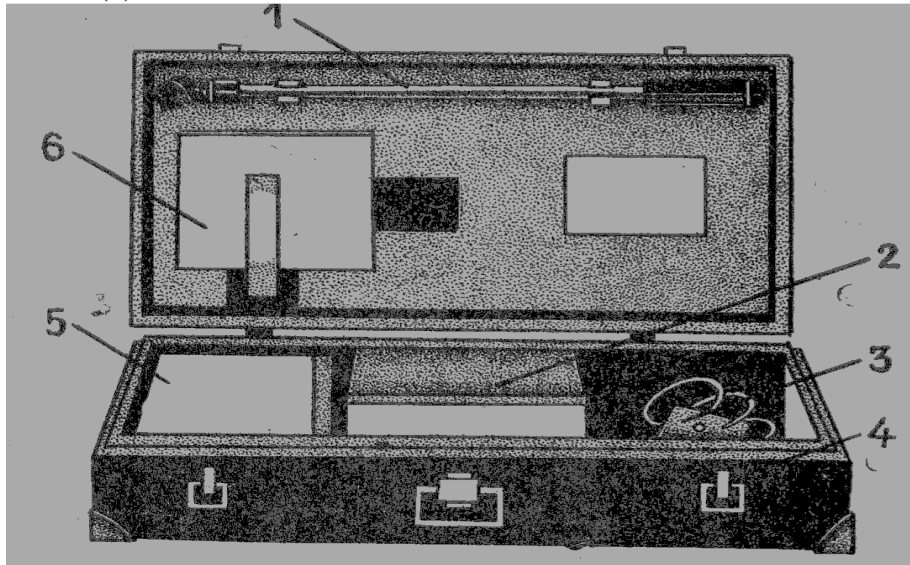

Picture 2. Composition of the kit

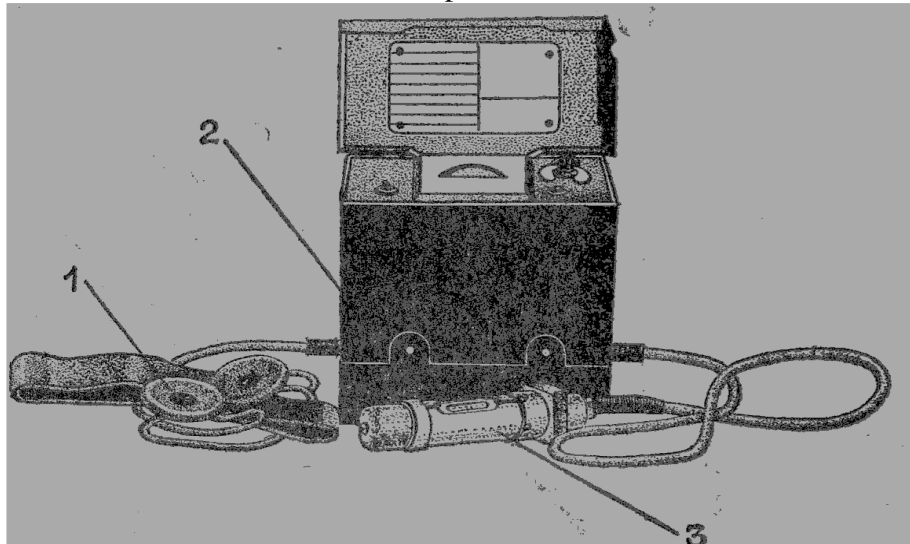

Picture 3. Meter in the cover
1-earphones; 2-cover; 3- GM probe

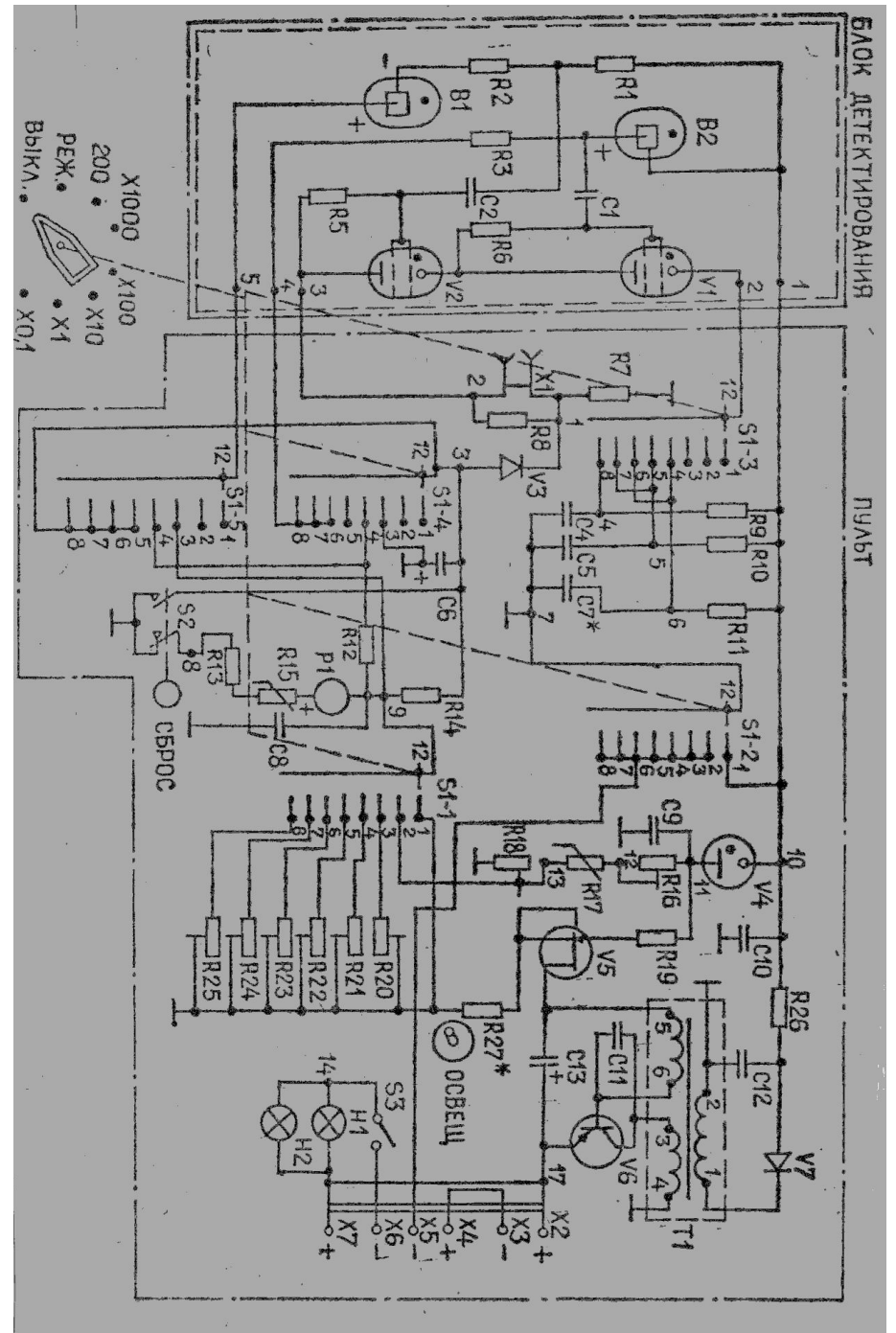

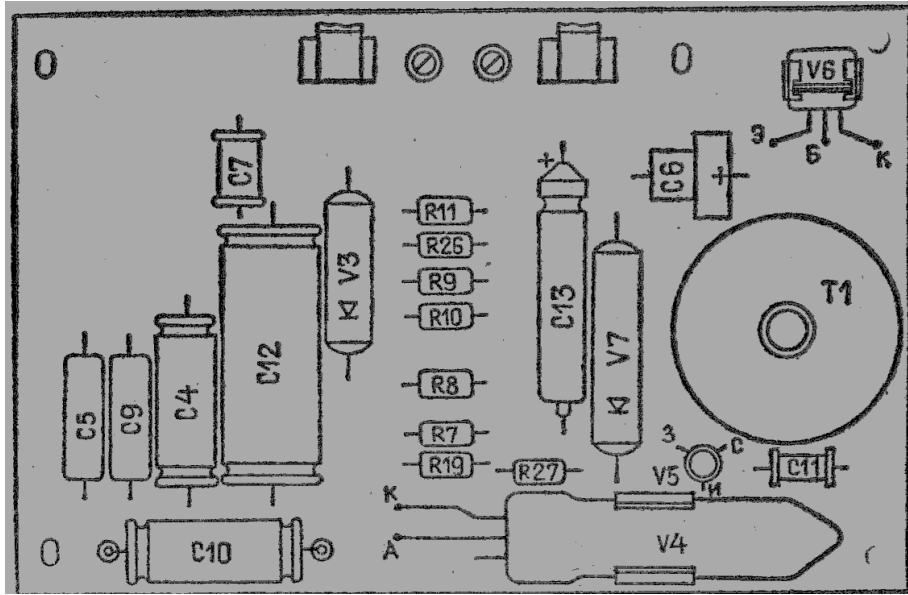

Pic.2. Main PC Board Layout

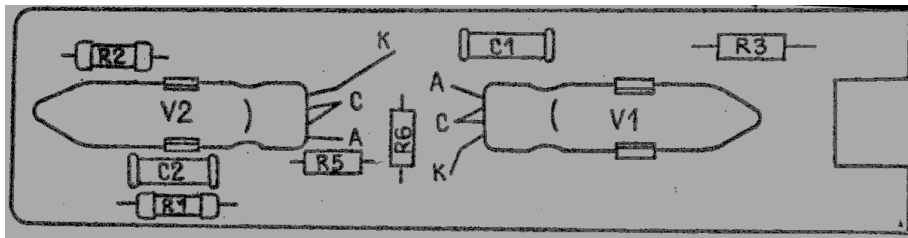

Pic.3. Diagram of the GM probe U4

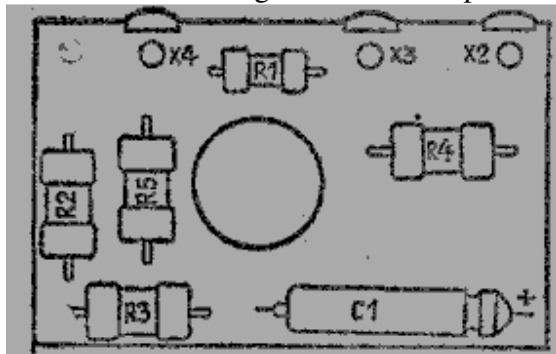

Voltage Divider. External Power Adaptor

4.2. The cover (pic. 3) for the meter is an imitation of leather. It has three parts, the main part for the meter, for the GM probe and for batteries. You can attach two carrying straps to the cover.

4.3. Earphones (1) (pic. 3), of the type TG-7M, are made from two small earpieces, and a head-band, which is made from a soft material.

4.4. The voltage divider allows supplying the unit from an external source of energy. You can use 12 or 24 DC Volts (selected via switches). The cable has a length of 10 meters.

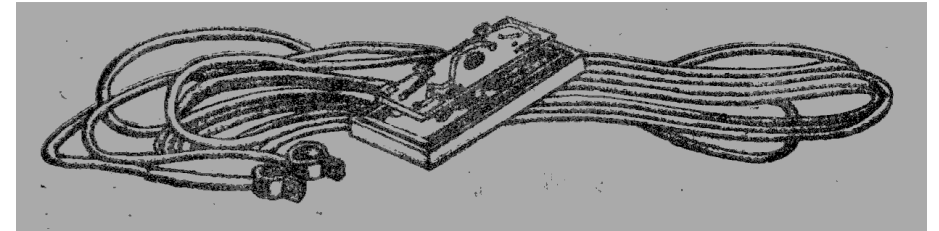

Pic. 4. Volatge Divider

4.5. The kit contains a telescopic wand (pic. 2), which can be used with the GM probe. Its length is from 450-750 mm.

4.6. The case is used for transport and protection of the whole kit.

5. COMPOSTION OF THE UNIT AND OPERATING

5.1. Composition of the unit

5.1.1. The meter has these parts: the main unit (1) (pic. 5), GM probe (3), a 1.2 m cable (2) between the GM probe and the main unit. There is a radioactive check source mounted on the GM probe (4).

5.1.2. The main unit has these parts: cover, base, cache, a table for conversion of measurement units, and the lid.

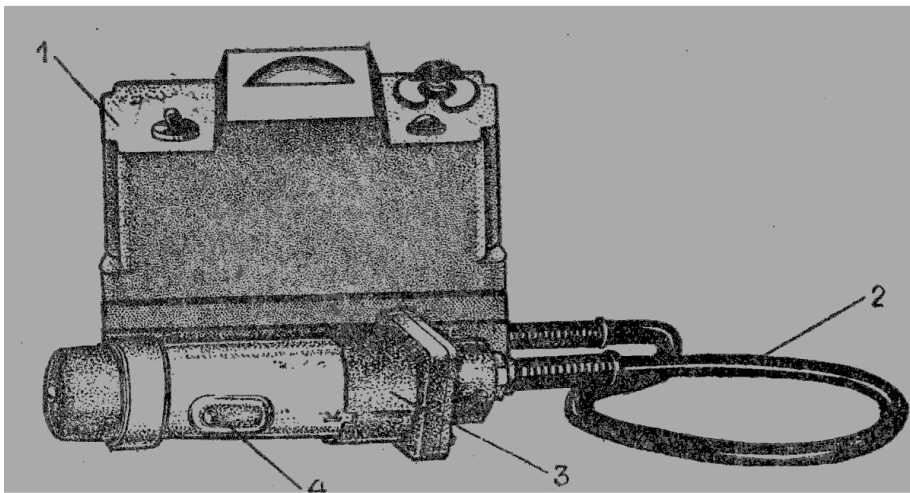

Picture 5. DP-5V

5.1.3. The cover, cache and the front are made from a material with a high mechanical ruggedness.

There are, in the front of the unit (pic. 6), these elements:

- A switch, to turn on or off the light for the scale  (1);
- Microampere scale (2);
- The range switch, 8 positions (3);
- Push-button to zero the readings \times (4).

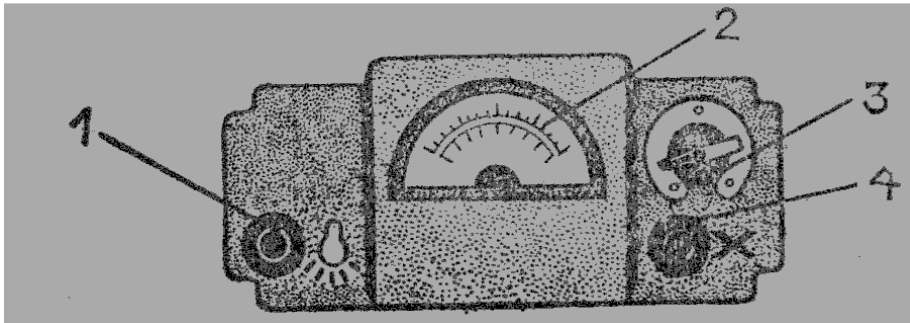

Picture 6. Front of the unit

There are, in the front of the unit, all controls for this meter. A cable is attached to the main unit, which is connecting the main unit with the GM probe and the earphones.

5.1.4. There is in, the backside of the main unit, a place for three A336 batteries. The kit contains also a voltage divider, which is attached instead of the three batteries.

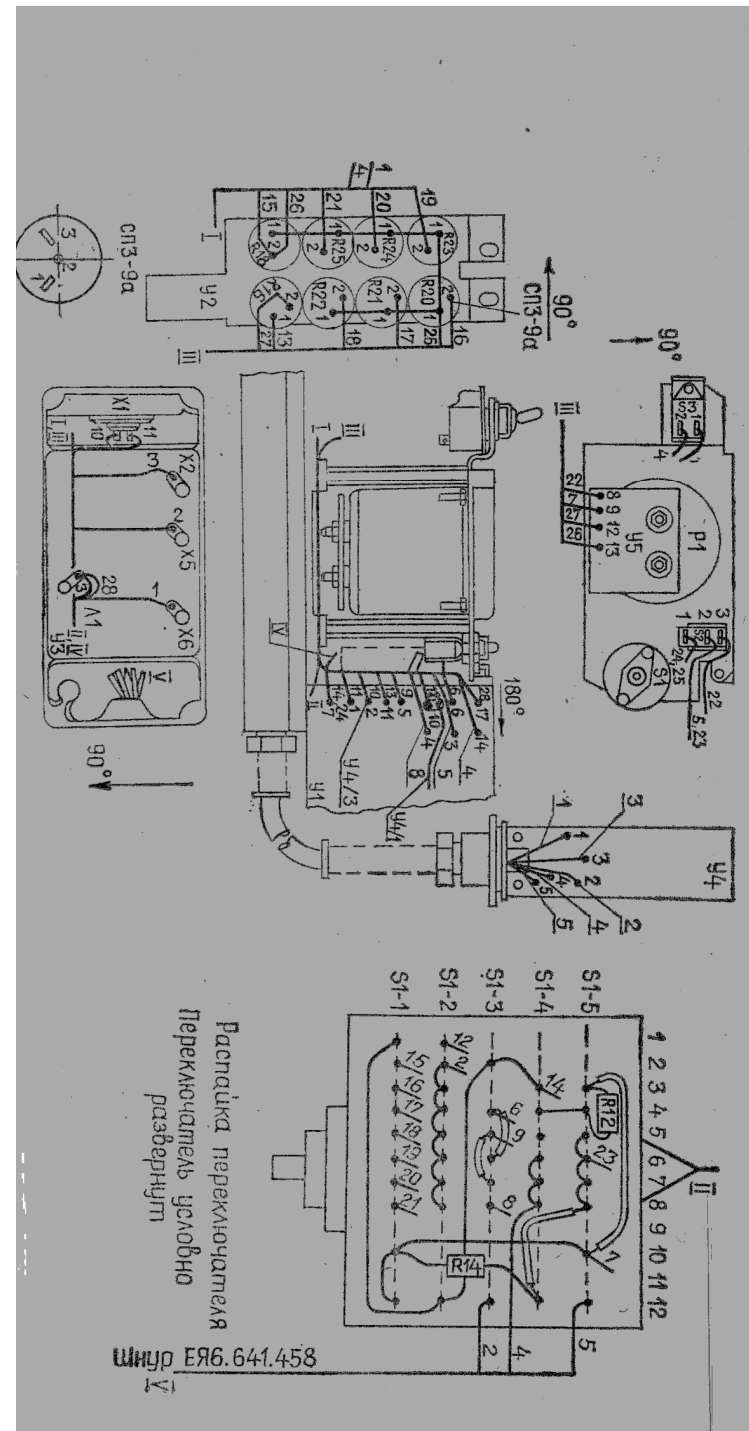

Pic. 1. Wire installation

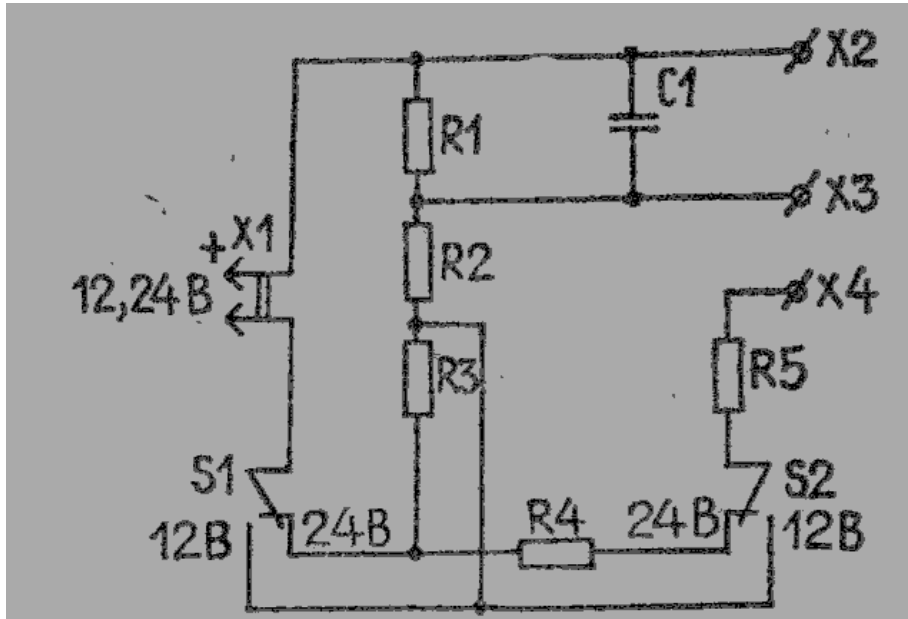

Pic2 Voltage Divider diagram

Index of used electric parts in the Voltage Divider

R1	43	Ohm	+/-10%	1W
R2, R3	120	Ohm	+/-10%	2W
R4, R5	82	Ohm	+/-10%	2W
C1	100 MF			6.3V
S1, S2	12/24V select slide Switches			
X1	Auto Battery Connection Terminal & Leads			
X2...X4	Geiger Counter connection Terminals			

The cover is connected with the inside elements with 4 screws. The case for batteries is closed with a special screw that doesn't fall out. The control panel is watertight.

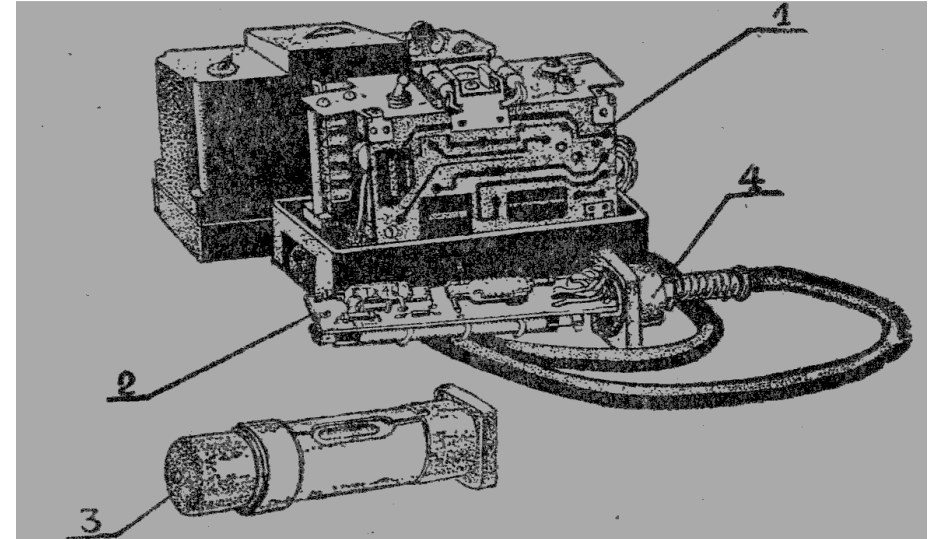

Picture 7. Inside of the unit.

1- HV transformer 2- GM probe plate 3- cover for the GM probe plates 4- flange(?)

5.1.5 The GM probe (3) (picture 5) is sealed and has a cylinder form. Inside are the plates (2), on which are the GM probes and other elements of the diagram. A cover, with a window for detecting beta radiation, is put over the plates of this GM probes. The weather seal of the GM probe is realized with rubber gaskets.

Grooves along the (GM probe) cover are for the exact alignment of the GM tubes to the window for detecting beta radiation. This arrangement determines the exactness, when testing the meter with the radioactive check source B-8. The GM probe has a sliding window, which can be fixed in these positions: B, G and K. When using the B position of the sliding window, the window is opened and you can measure beta radiation. If you use the G position, the window is closed, and all beta radiation is blocked (only gamma radiation is measured). In position K, the radioactive check source B-8, which is mounted in the sliding window, is placed above the GM probes. The cover is connected to the flange (4) with 4 screws

5.2. Principles of operating

High Voltage Circuit

The high voltage is generated by an oscillator, V6 which provides pulses to the primary windings of step-up transformer T1. Across the secondary winding of T1, high voltage pulses are created via transformer action. These pulses are rectified by diode D7 and filtered by C12, R26 and C10. Ionization tube V4 drops a certain amount of DC voltage and applies the remainder to the gate of feedback regulator V5. V5 in turn controls the strength of oscillations in V6, culminating in a closed loop electronic regulator. The final DC voltage (390-400V negative) is applied to the GM tube card in the probe head via an attached 5 conductor cable.

Probe Head

The probe contains the 2 Geiger Mueller tubes and Thyratrons. There is a high range GM tube and a low range GM tube. These make pulses from the incoming radiation, and those pulses are transmitted back to the main unit via the 5 conductor cable.

Main Unit

In the main unit are housed the battery compartment, HV section, metering unit and range switch. Calibration resistors R-20 through R-25 allow precise calibration by a laboratory.

To remove the range control knob, loosen the central screw with a screwdriver, then push down sharply on the screw. There is a cam mechanism inside the knob, and this will free the cam. When replacing the knob be aware there is a round side and a flat side to the range control switch shaft. Make sure the knob is correctly reinstalled.

Addition 1

Index of electric parts used in the main diagram

R20	33K	Ohm	Calibration Control	
R21	15K	Ohm	Calibration Control	
R22	33K	Ohm	Calibration Control	
R23	15K	Ohm	Calibration Control	
R24, R25	22K	Ohm	Calibration Control	
R26	430K	Ohm		
R27	51	Ohm		.125Watt
S1			Range Switch	
S2			Meter reset to Zero Switch	
S3			Lamp Switch	
T1			High Voltage Generator Transformer	
V1, V2			Thyratron tube	
V3			Diode	
V4			Regulator Tube	
V5			Voltage control FET	
V6			HV Osc Transistor	
V7			High Voltage Diode	
X1.....X7			Battery Terminals	

Index of parts used in the main diagram

B1	Small Glass GM Tube	CN3bL	400V
B2	Large Metal GM Tube	CbM-20	400V
C1	15 pF +/-5%		750V
C2	47 pF +/-5%		750V
C4	.01 +/-10%		750V
C5	1000pF+/-10%		1300V
C6	20MF +/-20%		50V
C7*	15pF factory selected		750V
C8	.01 +/-10%		200V
C9	4700pF+/-10%		200V
C10	.025 +/-10%		500V
C11	6800pF+80%-20%		70V
C12	.1 +/-10%		750V
C13	K50-29-160 B-1		
H1, H2	Lamp	1V .068A	
P1	Meter Movement	10uA	
R1	2M Ohm		.25Watt
R2	2.2M Ohm		.25Watt
R3	5.1M Ohm		.25Watt
R5,R6	47M Ohm		.25Watt
R7	220K Ohm		.125Watt
R8	1K Ohm		.125Watt
R9	510K Ohm		.125Watt
R1, R11	2M Ohm		.125Watt
R12	180K Ohm		.125Watt
R13	4.7K Ohm		.125Watt
R14	510K Ohm		.125Watt
R15	82 +/-20%	Thermistor	
R16	150K Ohm	Control, HV set	
R17	620 +/-20%	Thermistor	
R18	6.8K Ohm		.125Watt
R19	1.5M Ohm		.125Watt

15. Transport

15.1. Cover, packing and marking the coffer.

15.1.1. The supply of these meters is made in special transport coffers, each of them has 3 meters, and the weight with the meters is not more than 40 kg. Parameters of the coffer are 695 x 623 x 465 mm. The marking of coffers is made by using a special paint. Each coffer has 2 sealings.

15.2. Conditions of transport

15.2.1. This unit can be transported in these conditions of temperature and relative air humidity:
temperature from -50 to $+60^{\circ}\text{C}$, $95\% \pm 5\%$ by a temperature of $40 \pm 2^{\circ}\text{C}$

15.2.2. This unit can be transported with all types of transport. In the transport coffer protected from all atmospheric conditions.

6. Marks and sealings

6.1. There is a registration number printed on the main unit and there is the name of the unit.

6.2. The unit has sealings in hollows under screws. All components are in the transport case, which has two sealings near the locks.

7. Instruction for, and after use

7.1 General instructions after use

7.1.1. Care for a general protection of your unit against dust and dirt.

7.1.2. Don't leave it turned on, if you have a pause. This can result in discharging of batteries and to a decrease in power.

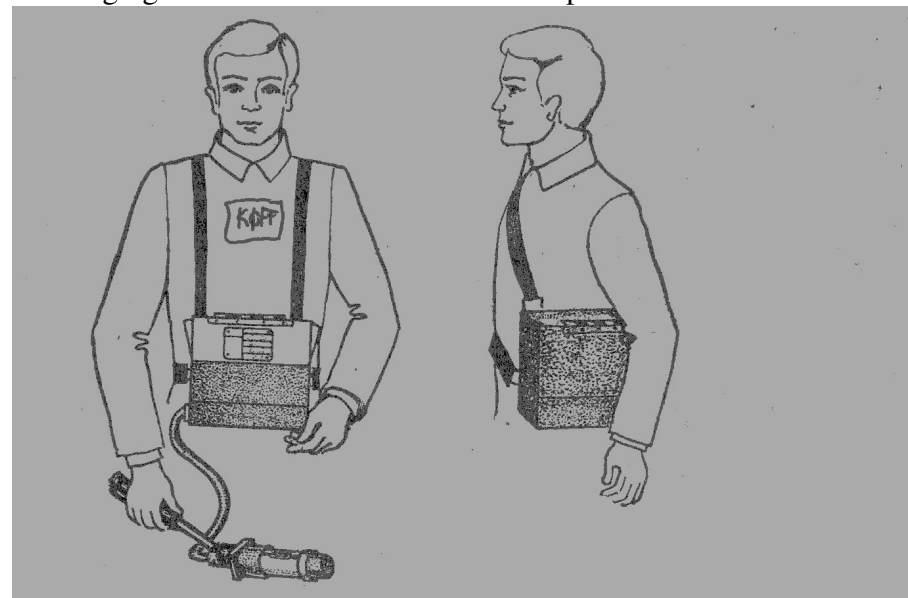

Operating position

Standby position

Picture 9. Scheme of wearing

7.1.3. Don't use force to turn the range switch back to its normal position.

7.1.4. Execute the unit, check, if there is everything, what should this kit have. If you are preparing to get this unit standby. Check your unit for work. Place the checked unit, with the cover, into the coffer. It's now read to work.

This unit is transported with cars, and:

Protect it against falls, shocks etc.

Store this kit, if possible, in the front part of your car (not in the boot).

Always check this unit after work or after transport (table 3).

7.1.5. In time of use, this unit can be worn in two positions: operating position and standby position. (picture 9)

8. Margins of safety

8.1. If you use this unit, follow these safety instructions:

Be in a most possible distance from the measured radioactive source.

Try to reduce the time, if you are searching the radioactive source.

Try to reduce the time, of remaining the personnel in the contaminated zone or in the near of a container with a radioactive source.

Always wear charged DK-0.2 dosimeters, if you work with radioactive materials.

8.2. If you are inspecting or disassembling the unit, it's necessary to use only instruments with electrically isolated handles, because the GM tubes and other components are using a high voltage of 390-400 Volts.

9. Preparation for work

9.1. Learn all technical instructions for work

9.2. Make a decontamination, disinfection or degassing of this unit if needed. The decontamination, disinfection or degassing is realized in a special room.

is made with these following instructions:

- Oil all unpainted metal parts of the storing case with a rag impregnated with petrol.

And then use the oil OKB-122-7 GOST 18179-72.

Wrap the unit after oiling in a greaseproof paper.

14.3. If you are storing the units for a longer term, the unit is preserved in a hermetic sealed box GOST-16354-82 made of polyethylene and using desiccant GOST 3956-76.

Wrap the box with a special paper GOST 8273-75.

Insert 3 desiccants into the box (200 g each). One of them is for checking and it's marked with the letter K.

Place an indication paper on a visible place. Seal the polyethylene box (inside with the DP-5V) so you can provide weather seal.

The humidity content in the desiccant can't be higher than 2%. The desiccants are dried on an oven with a temperature of 200-250 °C, about 3-5 hours. The preserved units can be stored 2 years. Make an inspection after the first year. Open 5 % of your stored units and take out the control desiccants. If the humidity in the desiccants is not more than 18 %, give they back and seal the box.

If the humidity in the desiccants is higher than 18 %, the unit has to be reactivated.

14.6. The unconservation after a short term of use is made with these following instructions:

-take out the meter from the case

-remove the lubricant from the unpainted part by using petrol.

The reactivation after a longer term of storing is made by taking out the meters from the polyethylene boxes.

14.5. The meter can be stored 5 years. The serviceable life is 15 years. And the technical life is 25 000 hours.

the calibration is made with these following instructions:

Open the meter (don't forget to take off the range switch) and make an access to the resistors R20-R25 (diagram 1).

Set the range (resistor), which accuracy is over the limit. Expose the GM probe to a known radiation source. If the units accuracy is more $\pm 30\%$ higher than the true dose. Use the appropriate resistor to calibrate the unit. Again make an accuracy check. Fix the resistor using paint.

13.5.2. After calibration, the unit needs to be completely tested.

14. Safekeeping of unit

14.1. This unit has to be stored in a coffer, in heated rooms. But it's permitted to store them in un-heated rooms too.

Conditions of storing:

air temperature from $+30$ to -30 °C, permitted relative air humidity 98% by a temperature of 25 °C. Safekeeping against higher air humidity is made by using conservation.

Only a working unit without inserted batteries should be stored.

The conservation is made in a special room, with a temperature not less than 15 °C and the relative air humidity not more than 70%.



14.2. If the unit is stored for a short term (max. 12 months). The conservation

9.3. Take out the components of this kit, out from the case, attach the telescopic wand to the GM probe. Open the cover, and familiarize yourself with the control panel, and how to use it (picture 5.1.3.) Make a general inspection; attach the carrying straps to the cover. Change the position of the range switch to . Connect the power source.

9.4. Change the range switch to the position  (battery check). The needle has to move to the black zone on the scale.

Note: If the needle doesn't move absolutely, or if the needle doesn't move to the battery check sector (black). You need to check, if the batteries are not discharged.

9.5. Turn the light for the scale on (if needed).

9.6. Change the range switch to these positions: x1000, x100, x10, x1, x0.1. Check the ability of work on all ranges except the first, by using the radioactive check source B-8, which is attached on the GM probe's sliding window. You need to slide the window to the position K, and connect the earphones. You should hear clicks in the earphones. The needle has to stabilize on a point in the 6th and 5th range, the needle should incline on the 4th, 3rd and the on 2nd range the needle sometimes doesn't move, by reason of a small activity of the radioactive check source. The clicks in the earphone can periodically interrupt, on the 6th range, by reason of high activity of the radioactive check source. Click the button SBROS (). The needle has to stabilize on the zero position. Slide the window to the position G. Change the position of the switch to . It's ready to use.

10. Discipline of work

10.1. Measuring the Gamma radiation

10.1.1. In the position G (rotating window), this unit measures only Gamma radiation, in the place where is the GM probe is located. On the first range, the readings are shown on a scale from 0-200, on other ranges the readings are shown on a scale from 0-5. These readings are multiplied with the coefficient of the relevant range. To determine, if the clothes, body, etc. are contaminated with radiation particles, the GM probe should be about 1-1.5 cm from the measured material.

10.2. Detection of Beta radiation

10.2.1. Turn the rotating window, of the GM probe, to the position B. (window exposed)

10.2.2. The GM probe should be in a distance of about 1-1.5 cm from the measured material. Turn the range switch to these positions x0.1, x1, x10 until you get a reading (the needle moves).

10.2.2. In the position B, you can measure beta and gamma radiation. If the measured item shows higher readings after opening the sliding window, then this material has beta radiation also. Turn the off after work.

Note 1: If you work with this unit, and if you turn the range switch to the position ▲, (battery check) the needle has to move to the check position (marked with black on the scale)

Note 2: There are, in this kit, 10 plastic covers for the GM probe, which are made from polyethylene. These plastic covers are used for the probe, if you measure bulk or liquid material. A used plastic cover is decontaminated or destroyed.

10.2.3. If you need to increase the distance from the measured material, you can use the telescopic wand. You need to unbolt the screw, take out the intern wand, and attach it by screwing the screw back.

- The test the other ranges by using a calibrated source of Cobalt-60. The unit's accuracy is good if the difference between the true radiation and the shown data is not more than 30%.

13.4.1. Log the results of the inspection, and the accuracy on the range 4, in to the form 13

13.4.2. Units with a negative result (the accuracy is more than 30 %) need to be calibrated.

13.5. Calibration

13.5.1. The calibration is shown in the table 6.

Range	Position of the knob	Measuring unit	Calibration points		Calibration Unit on the diagram
			Main	Test	
1	200	R/hr	140	50 25	R20
2	x1000	mR/hr	4000	2500 1000	R21
3	x100	mR/hr	400	250 100	R22
4	x10	mR/hr	40	25 10	R23
5	x1	mR/hr	4	2.5 1	R24
6	x0.1	mR/hr	0.4	0.25 0.1	R25

13.2. Rules of the inspection and preparation

13.2.1. If you are making the inspection, it's necessary to obey these rules.

temperature 20+- 5°C

relative air humidity 65 +-15%

atmospheric pressure 100 +- 4 kPa

distance between the measured source of radiation and the GM probe at minimum 50 cm

background radiation at maximum 0.03 mR/hr

13.2.2. Before making the inspection, it's necessary to prepare for work, which is described in the section, Preparation for work,

13.2.3. All testing equipment has to work, tested and it's has to have an agreement of inspection from the state.

13.3. The inspection

13.3.1. Before the main inspection, the meter should be checked for defects. Units with defects are sent to repair.

13.3.2. The unit is tested for work with the sections 9.3., 9.4., 9.5., 9.6. in the part, "Preparation for use". Units with defects are sent to repair.

13.3.3. Unit's accuracy is tested with this:

- Take the GM probe to a source of 140 R/hr (and don't forget to keep your distance)
- Switch the range knob to the position 200
- Repeat the measuring at minimum 3 times

11. Characteristic defects and their repair

11.1. Characteristic defects and their repair are shown in the table 2.

Table 2

Description of the defect	Possible cause of the failure	How to repair
1. The typical sound (buzz), if the unit is turned on, is missing.	1. The battery contacts are not clean.	1. Clean the battery contacts with a sharp item (knife, emery paper)
2. When checking the batteries with the battery check, the needle does not stabilize on the black sector,	1. The batteries are discharged. 2. The transistor V5 or V6 is bad.	1. Open the battery cover, take out the old A336 batteries and insert new batteries. 2. Open the unit (don't forget to take out the range switch). Take out the wrong transistor and replace it for a new one. (11.2.)
3. I can hear the quiet buzz of the oscillator, but If I test it with the battery check, the needle doesn't move.	1. Stabilizer V4 has gone bad.	2. Open the unit (don't forget to take out the range switch). Take out the wrong part and replace it for a new one.

Description of the defect	Possible cause of the failure	How to repair
<p>4. The 2 bulbs of the meter do not work or they are lighting very weak.</p> <p>5. When measuring the normal background radiation on the ranges 1, 2, 3, the needle does not move. There is a hum in the earphones.</p> <p>6. When measuring radiation on the ranges 4, 5, and 6, the needle does not move. There is a hum in the earphones.</p> <p>7. When calibrating the unit, the needle does not move or it "jumps".</p>	<p>2. A cable is somewhere cut short.</p> <p>1.The bulbs are burned out.</p> <p>2. The batteries are discharged.</p> <p>1. The GM tube B-1 has gone bad.</p> <p>2. One of the thyratrons V1 or V2 is broken.</p> <p>1.The GM tube B-2 has gone bad.</p> <p>2. One of the thyratrons V1 or V2 is broken.</p> <p>1.One of the resistors R20, R21, R22, R23, R24 or R25 is bad.</p>	<p>2. Find the abrupt cable and repair it.</p> <p>1. Open the unit and replace the bulbs</p> <p>2.It's the same progress as in the defect 2.</p> <p>1. Unbolt the 4 screws of the GM probe, take out the bad GM tube and replace it for a new one (remain the polarity)</p> <p>2. Unbolt the 4 screws of the GM probe, take out the bad thyatron and replace it for a new one.</p> <p>1. Same as before.</p> <p>2. Same as before.</p> <p>1. 1. Open the unit and replace the wrong resistor.</p>

Notes

Inspect the location for batteries. If all rubber gaskets are present, no corrosion on battery contacts, clean the contacts from all dirt. Make certain the no humidity is inside and check whole battery cover.

12.6. Checking the paint

12.6.1. Make a general inspection of the paint, search for any defects. Repair the paint with using these paints NC-1125 and GOST 7930-73. And it's necessary to keep the color shade. Before painting, it's needed to clean the painted material. If the paint is too heavy damaged, the repainting is made in a repair shop.

12.7. Logging the work in a work-book

12.7.1 Execute the notation of the time of work to the special work form, section 10

13. Inspection of the meter

This following section is written in compliance with GOST 8.313-78 <<Dosimetric units for measuring Gamma radiation, with the strength of the photons from 10 to 50 fDz (from 0.06 to 3 MeV)>> The inspection is made every year for all units which are used continuously or periodically. And every 2 years for unit which are not used (stored).

13.1. Operations and equipment for testing

13.1.1. If making a inspection, it's necessary to used the related equipment from the table 4

Table 2

Description of the defect	Possible cause of the failure	How to repair
8. The battery check is OK. The GM tubes work, but if measuring on ranges 2-6, the needle does not move.	1. One of the capacitors C4, C5 or C6 has gone bad.	1. Open the unit and replace the wrong capacitor.

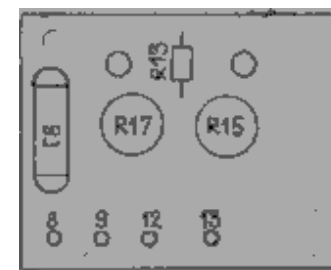

12. Maintenance engineering

12.1. A list operation and their order for the maintenance of this unit, are show in the table 3.

Table 3

These things need to be checked:	Maintenance type			Procedure number
	By regular using		If not used a longer time (every 5 years)	
	Every day	Every half-year		
Visual inspection	Yes	Yes	Yes	12.2
Contents check	Yes	Yes	No	12.3
Ability to work	Yes	Yes	Yes	12.4
Took out batteries	Yes	Yes	No	12.5
Check the paint	Yes	Yes	Yes	12.6
Log the work	Yes	No	No	12.7
Whole inspection	No	No	Yes	13

12.2 Visual inspection

12.2.1. Inspect the kit with these following instructions.

- a) Clean the coffer (in and out) from all dirtiness.
- b) Check the function of the whole mechanism coffer, locks, paint, and rubber seals...
- c) Inspect the meter cover for deterioration, if the wearing straps are well connected.
- d) Inspect the meter's surface, if the sealings are present, search for scratches, corrosion and defects of the cover.
- e) Inspect if the button SBROS (X) works, if all controls are good attached and work, if the range switch works, if there are any other defects.
- f) Check the GM probe and the cable, search for defects, wrinkles, corrosion and defects of the cable. Fat the coatless parts with oil impregnated in a shred.

12.3. Contents check

12.3.1. Check if all contents of this kit are present. If every part has it's place, and if it works. Also check, if there is a maintenance manual.

12.4. Ability to work check

12.4.1. Check the ability to work by reading the chapters 9.3 – 9.6 of this manual.

12.5. Batteries

12.5.1. If the batteries are taken out is checked after finishing the work.

Shutdown the radiation meter, open the battery cover and take out the batteries.